

REGENT'S

WatchGuard120™

SENSING RELAY

Features

- Object or ground sensing with safe (low voltage, low current) sensing circuit.
- Input can be contact, probe or solid-state sensing device.
- Two output poles, independently convertible from normally-open to normally-closed.
- Complete isolation between line, load, and logic terminals.
- Compact size. DIN rail or panel mount.
- LED status indicator for each output pole.
- Regent's 2 Year Warranty.

Ideal for:

- ▶ Part presence or absence detection
- ▶ Liquid level control
- ▶ Web break detection
- ▶ Position control
- ▶ Feed limit switch
- ▶ Wire break detection
- ▶ Intrinsic safety barrier interface relay



The *WatchGuard120* senses the closing of external contacts or sensors. It is ideal for monitoring part presence and liquid levels in industrial environments.

An isolated internal power supply provides low voltage sensing to any contact, positioning electrode, limit switch, magnetic reed switch, float switch, proximity sensor, etc. The low-energy sensing circuit increases the life of reed switches and other contacts by eliminating inrush current at turn-on and arcing at turn-off.

Because it responds to a drop in resistance, the *WatchGuard120* will respond to the closing of "dirty" contacts: a contact resistance below 25K ohms will energize the relay.

When the *WatchGuard120* senses a closed contact, its two solid-state output switches energize. Field-proven AC output poles can control 120 VAC industrial loads such as solenoid valves and contactors, or serve as logic inputs to programmable controllers.

FOR MORE INFORMATION CALL 203-732-6200
OR VISIT US ONLINE AT www.regentcontrols.com



e-mail: sales@regentcontrols.com



Regent's WatchGuard120™

Sensing Relay

DIMENSIONS

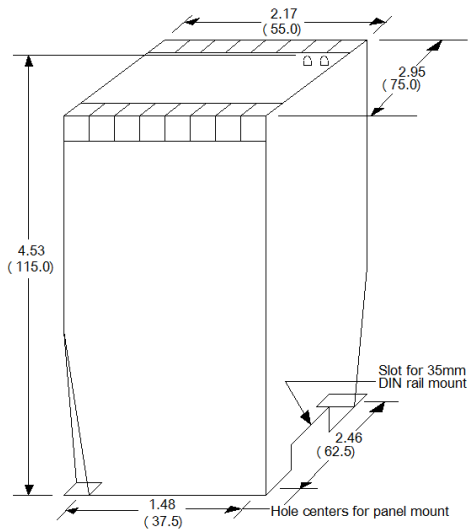

WIRING DIAGRAM

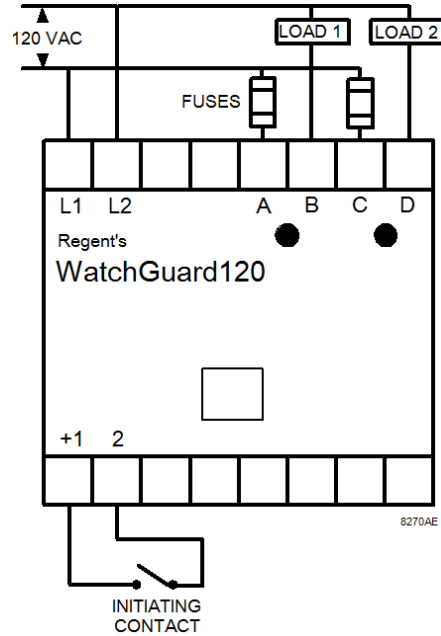

NOTES

1. Either output pole can be used to provide a latching function.
2. Terminals L2 and/or 2 may be grounded.
3. For loads greater than 1 amp, do not parallel solid-state switches. The current will not divide equally and may result in damage.
4. On removal of L1,L2 voltage, both A,B and C,D open.
5. Up to 5 output switches (A,B and C,D) from several *WatchGuard120's* may be used in series.

SPECIFICATIONS	<i>WatchGuard120</i>
Line Input (L1,L2 terminals)	120 VAC +/- 20%, 50/60 Hz
Sensing Input (1,2 terminals)	
Open-circuit voltage (typical)	12 VDC
Closed-circuit current	less than 1 mA
Resistance Sensitivity (typical)	Pull in below 25K ohms. Drop out above 50K ohms
Load Switch (A,B and C,D terminals)	
Rating	120 VAC +/- 20%, 1A continuous, 5A inrush; resistive or inductive
Off-state leakage	less than 2 mA at 65°C
On-state voltage drop	1 VAC typical at rated current
Minimum load current	15 mA
Response Times	turn-on: <1 msec turn-off: 1-9 msec
Recommended load fuse	Littelfuse 322002
Temperature	0 to 65°C (32 to 149°F)

FOR MORE INFORMATION CALL 203-732-6200
OR VISIT US ONLINE AT www.regentcontrols.com



e-mail: sales@regentcontrols.com

